

Guide Pillar
Reference: FCA

Code: **G06**
DIN 9833

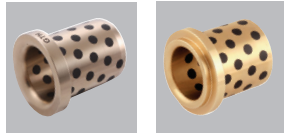
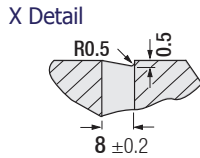
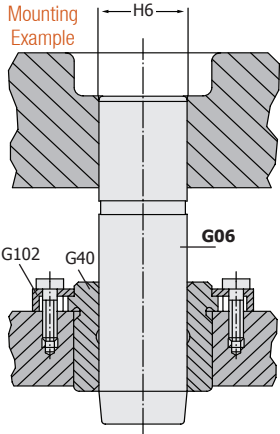

Code: **G06**

d mm	L mm	L1 mm	Form
32	160	45	A
	180		
	200		
40	200	56	A
	224		
	240		
50	224	70	A
	250		
	280		
63	250	80	A
	280		
	315		

d mm	L mm	L1 mm	Form
80	250	100	B
	280		
	315		
100	315	125	B
	355		
	400		
125	355	140	B
	400		
	450		
	500		
	550		

Order: **G06**. d x l

Material: 1.1213 (Cf53)
Hardness: 58 - 62 HRC

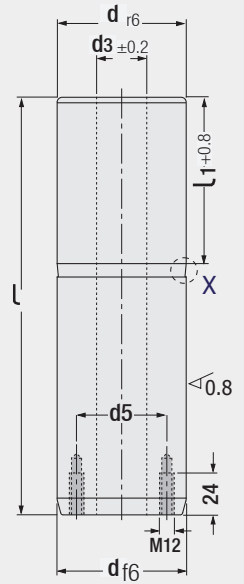
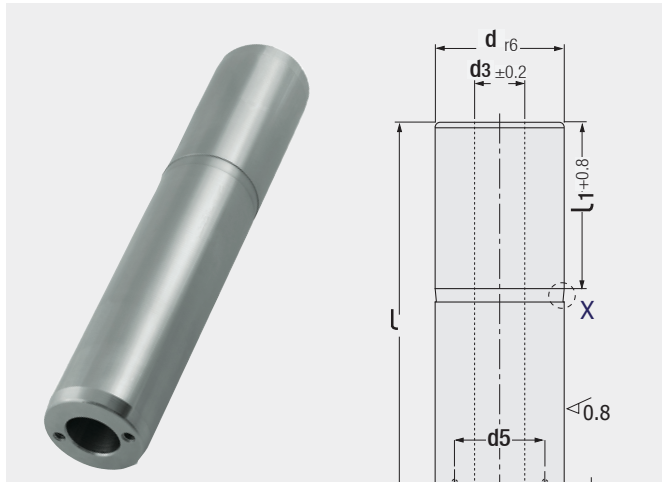

Guide Pillar
Reference: FCA

Code: **G07**
DIN 9833

Order: **G07**. d x l

Material: 1.1213 (Cf53)
Hardness: 58 - 62 HRC

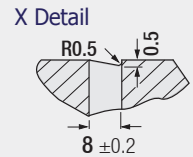

Code: **G07**

d mm	L mm	d3 mm	d5 mm	L1 mm
80	250	40	58	100
	280			
	315			
	355			
100	315	50	72	125
	355			
	400			
125	355	65	90	140
	400			
	450			
	500			
	550			

Guide Pillar & Bush Clamp

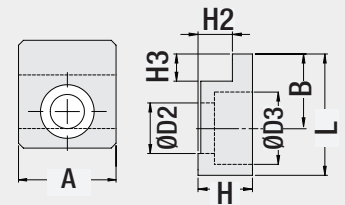
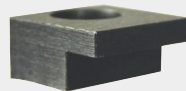

Order: **G102**. Form

Ø d1 Bush / Pillar	L mm	A mm	B mm	H mm	H2 mm	H3 mm	D2 Ø	D3 Ø	Form Screw
25 - 32	20	20	12.5	10	6.3	5	7	11	A M.6 x16
40 - 50									
63 - 80	32	32	21	16	10	10	11.5	17.5	D M.10 x25
100 - 125									
160									